



City of Wichita Falls

Site No. _____
Receipt No. _____
Date Rcvd. _____
For Office Use Only

## Wichita Falls-Wichita County Public Health District

1700 Third St. | Wichita Falls, TX 76301 | 940-761-7800 | www.health.wichitafa.tx.gov

### APPLICATION FORMOBILE FOOD ESTABLISHMENT PERMIT Incomplete Applications will not be approved.

Name of Establishment: \_\_\_\_\_ Phone: (\_\_\_\_) \_\_\_\_\_  
 Fax: (\_\_\_\_) \_\_\_\_\_ E-Mail: @ \_\_\_\_\_  
 Owner's Name: \_\_\_\_\_ Phone (\_\_\_\_) \_\_\_\_\_  
 Mailing Address: \_\_\_\_\_ City/State/Zip: \_\_\_\_\_  
 Emergency Contact Person: \_\_\_\_\_ Phone: (\_\_\_\_) \_\_\_\_\_

**Check appropriate box for each line:**

Establishment Ownership: Individual  Partnership  Corporation   
 Establishment Description: Non-Profit  Tax Exempt Number \_\_\_\_\_ For Profit  Mobile Unit

No annually permitted establishment shall allow temporary event food vending at their site unless a temporary event application has been submitted to the regulatory authority.

*The following permit fees are charged for retail food permits issued by the WFWCPHD for establishments located or operating in Wichita County, TX. All permits issued under this subdivision shall remain in force for one year from date of issuance unless removed/suspended by the regulatory authority. Permit fees shall be paid to the regulatory authority at the time of application; one week before a new establishment plans to open, or 15 days prior to the permit expiration for renewal permits. All permit holders, including nonprofits, that submit renewal applications and/or fees after the permit expires will be assessed a late charge. Any changes to the physical facility, menu, or equipment must be included in the renewal application. A complete application with updated information is required for each renewal permit. Please check the appropriate box that best describes your establishment:*

**Process 1:** Low to moderate risk. This process involves food sale with or without preparation and includes no cooking. Generally, the steps in this process are: Receive → Store → Prepare → Hold → Serve → Vend → Stock.

**Process 1 (Low to moderate risk): \$200.00**

**Process 2:** High risk. This process involves food preparation for same day service. Generally, the steps in this process are: Receive → Store → Prepare → Cook → Hold → Serve.

**Process 2 (High risk): \$225.00**

**Process 3:** Very high risk. This process involves complex food preparation. Generally, the steps in this process are: Receive → Store → Prepare → Cook → Cool → Reheat → Hot Hold → Serve.

**Process 3 (Very high risk): \$300.00**

**Seasonal Permits:** \$175.00 (1-6 mos. limit/No Very High Risk)

**ADDITIONAL FEES:**

A \$125.00 additional fee will be applied in addition to the above stated fees for EACH ADDITIONAL service:

Commissary (CM)  Grease Trap (GT@\$75)

Frozen dessert permit / certification: \$150.00.

**GRAND TOTAL PERMIT FEES DUE: \$ \_\_\_\_\_**

I (we) apply for a permit to operate a food establishment and by this application do agree to comply with the rules and regulations set forth by the Wichita Falls-Wichita County Public Health District. I (we) understand that any falsifications or omissions as to the material fact or any violation of any law by designees or myself will constitute grounds for revocation or suspension of this permit by the Health District.

\_\_\_\_\_  
 Signature of Applicant / \_\_\_\_\_ / \_\_\_\_\_  
 Print / Date



City of Wichita Falls

Site No.	_____
Receipt No.	_____
Date Rcvd.	_____
For Office Use Only	

## Wichita Falls-Wichita County Public Health District

1700 Third St. Wichita Falls, TX 76301 | 849-761-7800 | [www.health.wichitafalls.gov](http://www.health.wichitafalls.gov)

A current copy of a valid driver's license of the owner and each operator of the vehicle must be provided:

Name: _____	DL: State: _____ # _____
Name: _____	DL: State: _____ # _____
Name: _____	DL: State: _____ # _____
Name: _____	DL: State: _____ # _____

**Original license must be presented at the time of application, photocopy will not be accepted.**

A description of all vehicles to be used in the mobile food establishment operation along with the license or registration and vehicle identification number of said vehicles, and a copy of the current certificate of liability for all said vehicles

Make and Model: \_\_\_\_\_ Year: \_\_\_\_\_ VIN: \_\_\_\_\_

State License Plate #: \_\_\_\_\_ Exterior Color: \_\_\_\_\_

Make and Model: \_\_\_\_\_ Year: \_\_\_\_\_ VIN: \_\_\_\_\_

State License Plate #: \_\_\_\_\_ Exterior Color: \_\_\_\_\_

Make and Model: \_\_\_\_\_ Year: \_\_\_\_\_ VIN: \_\_\_\_\_

State License Plate #: \_\_\_\_\_ Exterior Color: \_\_\_\_\_

**Bring a copy of the automobile liability insurance for each vehicle permitted. A copy will be scanned into your records.**

I (we) apply for a permit to operate a food establishment and by this application, do agree to comply with the rules and regulations set forth by the Wichita Falls-Wichita County Public Health District. I (we) understand that any falsifications or omissions as to the material fact or any violation of any law by designees or myself will constitute grounds for revocation or suspension of this permit by the Health District.

_____ Signature of Applicant	_____ Print	_____ Date
---------------------------------	----------------	---------------



Wichita Falls-Wichita County Public Health District  
1700 Third Street, Wichita Falls, TX 76301, 940-761-7820  
[www.health.wichitafallstx.gov](http://www.health.wichitafallstx.gov)

**ANNUAL COMMISSARY OPERATOR'S AUTHORIZATION**

\_\_\_\_\_ (Mobile Establishment Owner's Name) of \_\_\_\_\_ (Mobile Establishment Name)

Street No. \_\_\_\_\_ Street Name \_\_\_\_\_ City \_\_\_\_\_ State \_\_\_\_\_ Zip Code \_\_\_\_\_ Phone No. \_\_\_\_\_

Has my permission to use my establishment as a commissary for storing and replenishing food and operating supplies, for washing and cleaning the mobile food establishment, for disposing of all solid and liquid wastes accumulated in the operation of the mobile food establishment, and for cleaning inside and outside the mobile food establishment.

I confirm and verify that my commissary meets all Texas Food Establishment Rule requirements including:

1. A hard surfaced area with overhead protection for supplying, cleaning and servicing the mobile establishment. Areas used only for the loading of potable water or discharge of liquid wastes through a closed system of hoses need not be protected.
2. Potable water servicing location with equipment that is installed, stored and handled to protect the water and equipment from contamination, and
3. A location for flushing and draining liquid wastes through a closed system of hoses that is separate from the location provided for water servicing and for loading and unloading food and related supplies.

I am attaching copies of my current health permit and the most recent health inspection report, which the mobile establishment operator must present to the Health Department at the time of making application for a mobile food establishment permit.

No. of Mobile units \_\_\_\_\_

Vehicle Plates _____	State _____	VIN _____
Vehicle Plates _____	State _____	VIN _____
Vehicle Plates _____	State _____	VIN _____
Vehicle Plates _____	State _____	VIN _____
Vehicle Plates _____	State _____	VIN _____
Vehicle Plates _____	State _____	VIN _____

Statement of Affirmation:

State of \_\_\_\_\_, County of \_\_\_\_\_,

I, \_\_\_\_\_ (Commissary Owner's Name) of \_\_\_\_\_ (Commissary Owner's Establishment), do solemnly swear that I have read the contents hereof and the foregoing statements are true in substance and effect and are made in good faith. I have read this letter notarized with my signature affixed and will provide servicing facilities for the mobile vendor identified above.

\_\_\_\_\_  
(Commissary Owner's Signature)

\_\_\_\_\_  
(Commissary Owner's Name)

\_\_\_\_\_  
(Commissary Address)

\_\_\_\_\_  
(Notary's Signature)

Commission Expires \_\_\_\_\_ day of \_\_\_\_\_ 201\_\_\_\_\_

NOTARY'S SEAL

## MOBILE VENDOR 'S MONTHLY AUDIT OF COMMISSARY VISITS

VEHICLE LICENSE PLATE#
------------------------

MOBILE VENDOR PERMIT#
-----------------------

By signing the block after the day of the month, the commissary operator certifies that the above licensed and permitted mobile food vehicle was serviced (cleaned inside, potable water loaded, and dirty water emptied) at the approved commissary on the date signed.

Month of _____, 20_____
-------------------------

DAY OF MONTH	COMMISSARY OPERATOR'S PRINTED	COMMISSARY OPERATOR'S
1		
2		
3		
4		
5		
6		
7		
8		
9		
10		
11		
12		
13		
14		
15		
16		

DAY OF MONTH	COMMISSARY OPERATOR'S PRINTED NAME	COMMISSARY OPERATOR'S SIGNATURE
17		
18		
19		
20		
21		
22		
23		
24		
25		
26		
27		
28		
29		
30		
31		

**This form must be available for auditing by health inspectors during all times that your mobile food vehicle is operating. Failure to maintain this form in the mobile food vehicle may result in suspension or revocation of your mobile food vending permit or other legal action.**

FLOOR PLAN FLOOR PLAN FLOOR PLAN

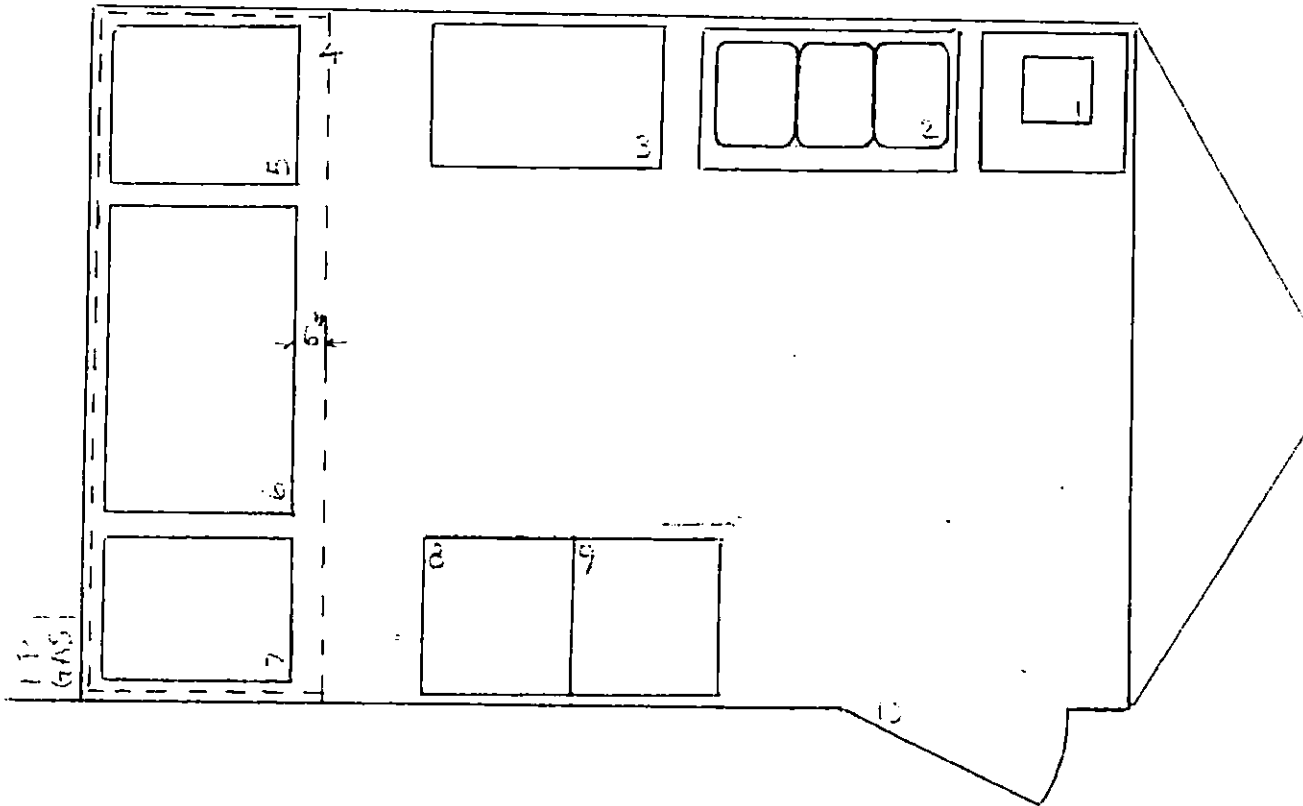

LEGEND

- 1 Hand Sink (stainless steel)
- 2. 3-compartment Sink (stainless steel)
- 3 Prep Table (stainless steel)
- 4. Vent Hood - Commercial, Type I with removable grease catch pan (installed under drain hole of slat-filters)
- 5. Gas Stove Range - Commercial
- 6. Gas Grill - Commercial
- 7. Deep Fryer (gas) - Commercial
- 8. Reach-in-Cooler
- 9 Reach-in-Freezer
- 10. Entrance/ Exit Door

NOTE:

- 1) Floor: Aluminum diamond plates
- 2) No exposed utility lines, piping, conduits, or wiring on walls/ ceiling
- 3) Ceiling & walls in Cook Line: stainless steel
- 4) Walls behind & beside 3-compartment sink & hand sink white FRP
- 5) Remaining walls & ceiling: smooth, non-absorbent, easily cleanable, & light in color. (white, oil-base-paint-on-plywood)

## PLUMBING

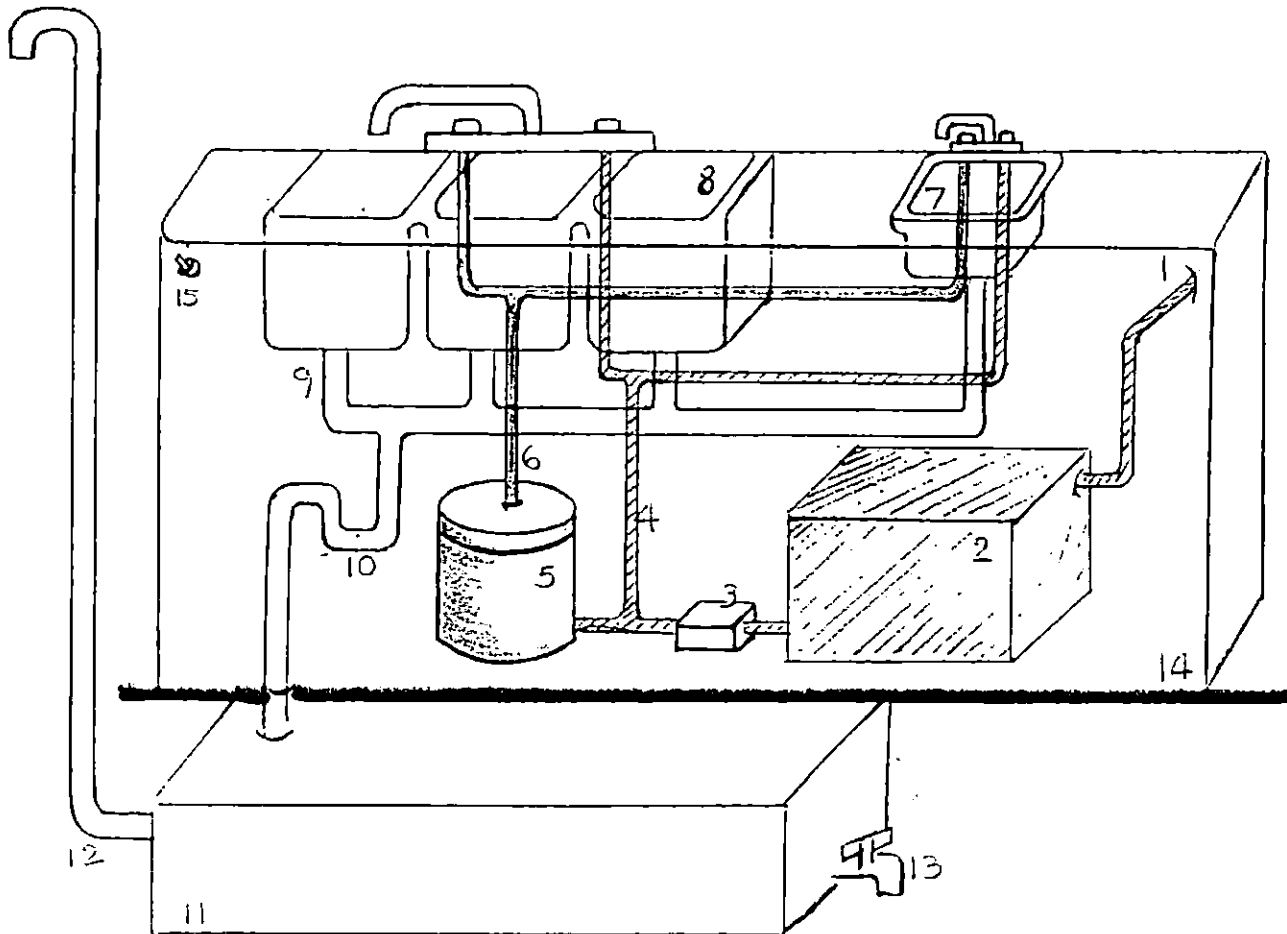

### LEGEND:

- 1 Fresh water inlet valve (1/2") with screen & protective cap (outside of unit)
2. Fresh water tank 40 GAL. Food-Grade Plastic (in enclosed cabinet)
3. Water pump
4. Cold water line - PVC 1/2"
5. Water heater
6. Hot water line - PVC 1/2"
7. Hand sink (stainless steel)
8. 3-compartment sink (stainless steel) with rounded internal corners & angles (15"Wx15"Lx12"D per compartment)
9. Drain pipe - PVC 1 1/2"
10. P-trap
11. Waste water tank. 50 GAL. (stainless steel) (outside, under floor, to the rear of unit)
12. Atmospheric vent pipe - PVC 1/2" extended outside & above sink level
13. Drain valve - PVC 2 1/2"
- 14 Enclosed cabinet with access door
15. "On/ Off" switch for water pump

# ELECTRICAL

*ELECTRICAL*

## ELECTRICAL

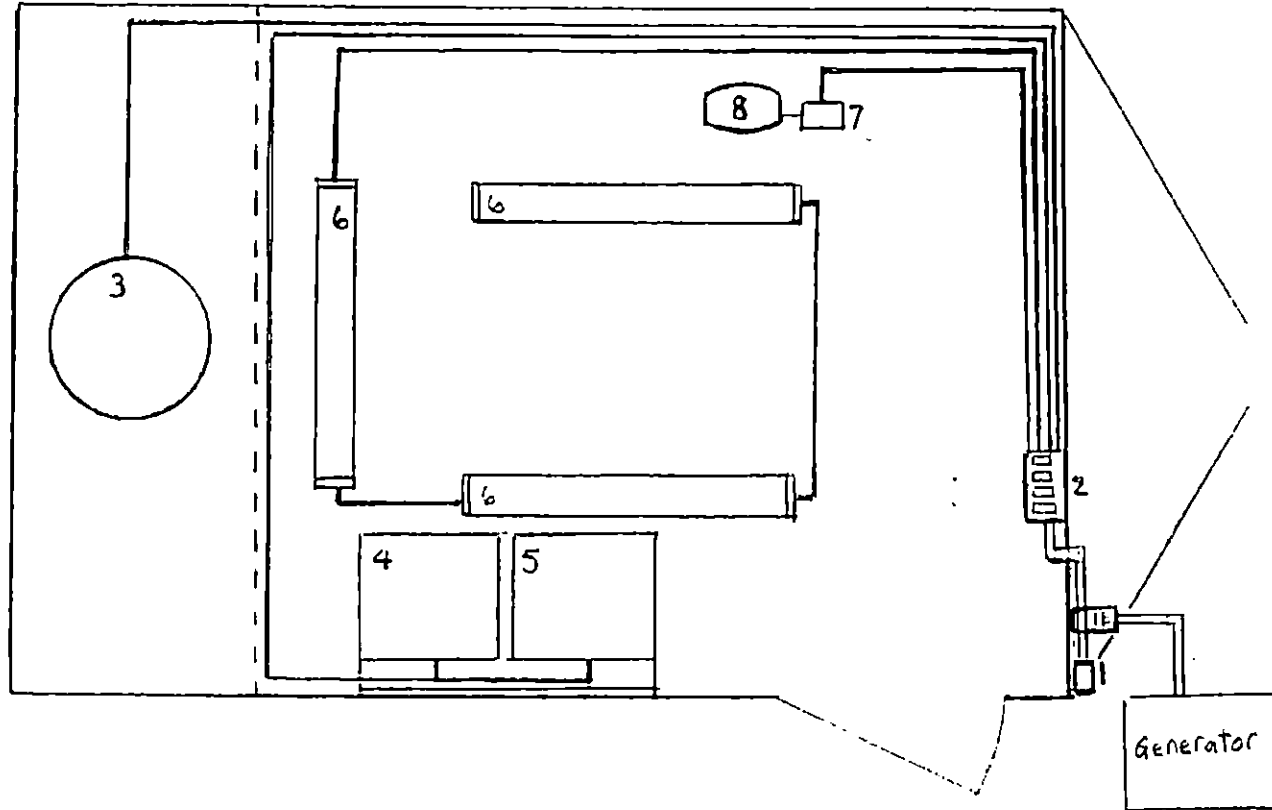

### LEGEND

- 1 Electrical Receptacle
- 1-b Transfer Switch
- 2. Circuit Breakers
- 3 Vent Hood/ Extractor
- 4 Reach-in-Cooler
- 5. Reach-in-Freezer
- 6 Lights with Light Shields
- 7 Water Pump
- 8 Water Heater

### NOTE

- 1) Power: Quick Connect, Single-phase 120V AC power
- 2) Alternate power. Generator
- 3) Lights T12, 4ft, 34W Fluorescent Lamps

# GAS

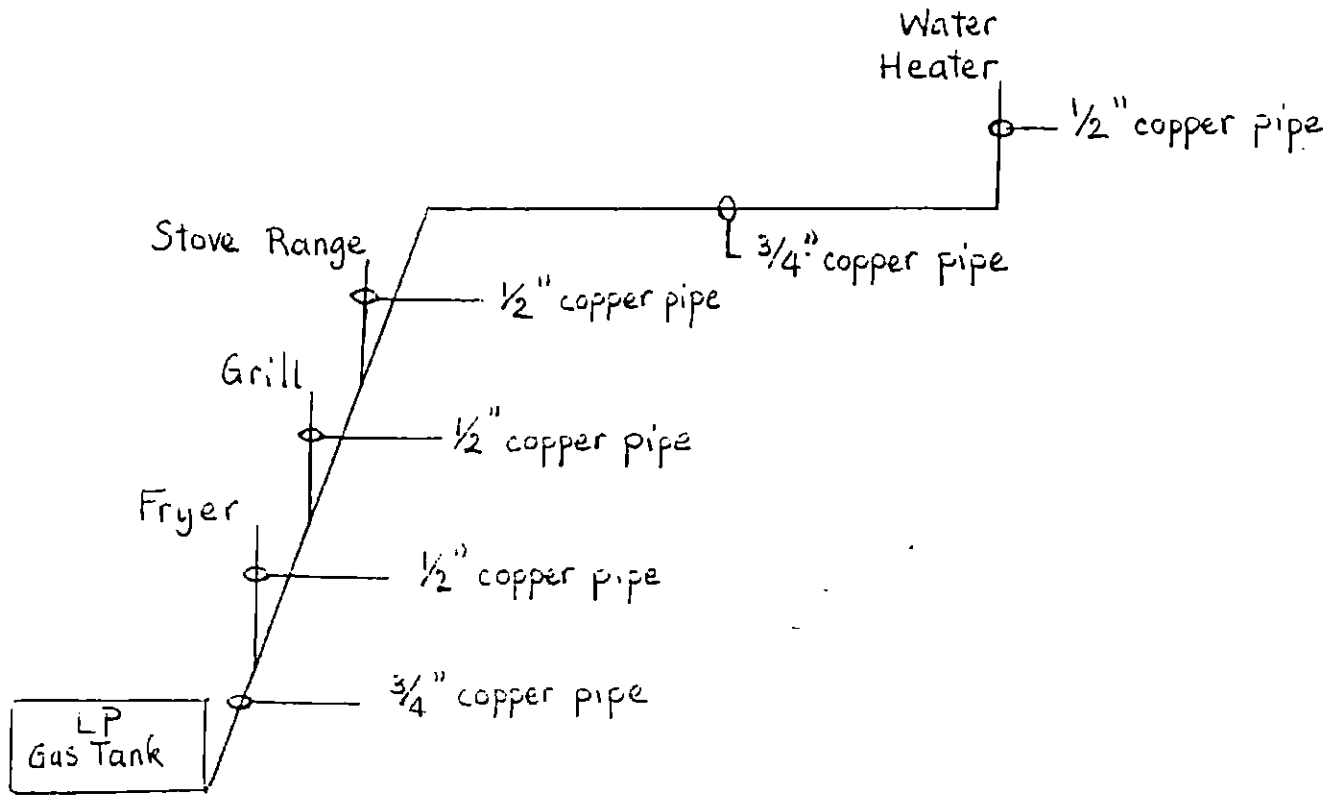



# EXTERIOR

## EXTERIOR

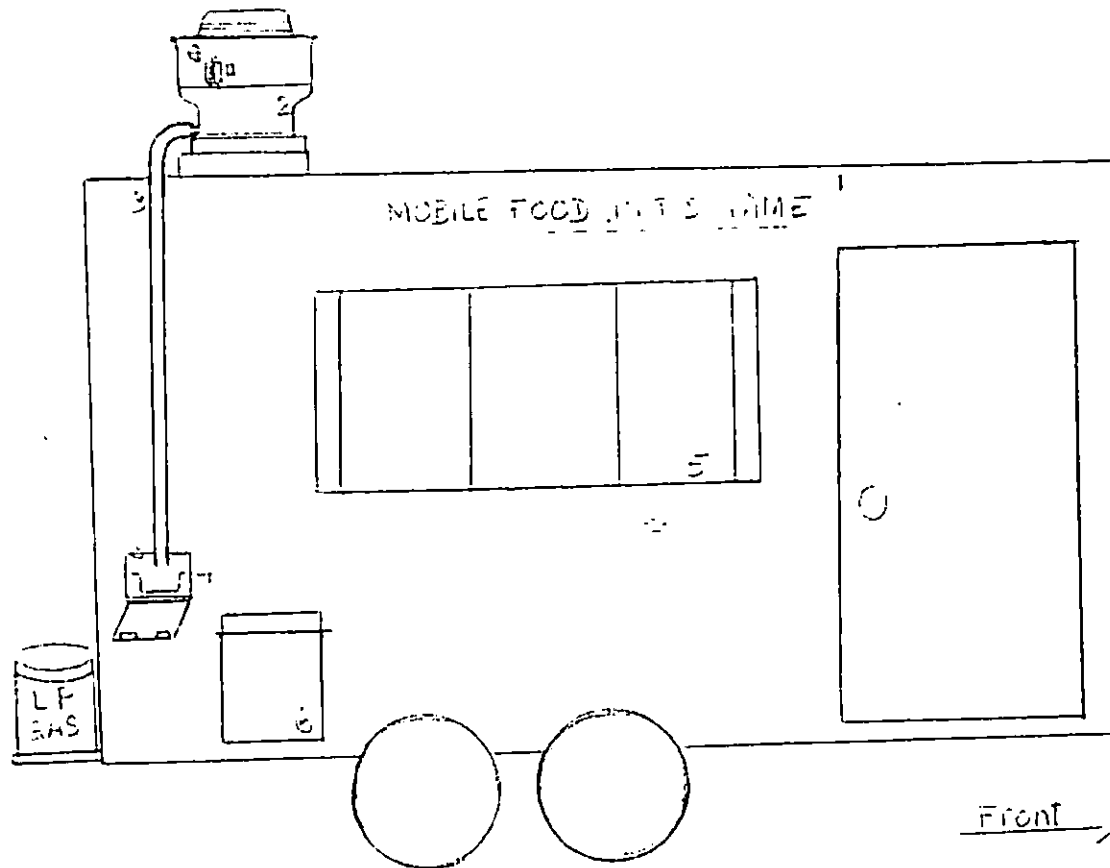

### LEGEND:

1. Business Name. Permanently affixed to at least 2 sides of unit, with readily visible letters of size at least 3" in height.
2. Extractor (of Vent Hood)
3. PVC Drain Pipe (sealed at junctures)
4. Stainless Steel Box (completely enclosed) with access lid & latches, & a grease catch pan inside
5. Windows with approved screens
6. 20 GAL. Waste Container with lid (Waste container securely attached to exterior side of Mobile Unit)

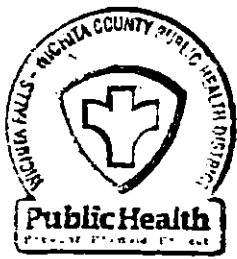

City of Wichita Falls

## Wichita Falls-Wichita County Public Health District

### Pre-inspection Unit Checklist: Check all these items before bringing unit to the Health District.

- Are walls and ceilings smooth, washable, easy to clean and light-colored?
- Are walls, ceilings, and floors in good repair?
- Are they clean?
- Is the equipment commercial grade?
- Is all equipment washable, easy-to-clean and in good repair?
- Is the refrigerator clean? Does it have an accurate thermometer?
- Is the cooking equipment clean?
- Are the floors in the cabinets clean?
- Does the vent hood extend beyond the cooking surfaces?
- Does the hood have a canopy?
- Is it a stainless steel commercial hood?
- Are the filters baffle-type and easy-to clean?
- Are they removable?
- Does the vent hood fan pull air?
- Are the filters installed at an angle between 45 degrees and vertical?
- Is there a drain and removable catch-pan at bottom back edge of vent hood?
- If the roof attachment has a drain on the side, does it have a drain pipe attached which extends down side/back of unit? Is there a catch-pan at the bottom of it?
- If unit has a 3-compartment sink, is the clean water tank at least 30 gallons?
- Is the waste-water tank at least 15% bigger than the clean water tank? (to calculate capacity in gallons: multiply length x width x depth in inches. Divide by 231.)
- Are water tanks accessible for measurement by inspector? (If not, you will need to bring potable water tank full and stoppers for compartment sink, so that capacity can be calculated by filling sink. In case of waste water tank, you will also need to bring extra water to show tank is 15% bigger than your potable water tank.)
- Is the clean water tank inlet located outside unit and away from waste-water tank outlet?
- Does it have a cap?
- Does the waste-water tank have a vent which comes from the top (or side near top) of the tank itself?
- Does the pipe extend to above level of sinks?
- Does it vent outside?

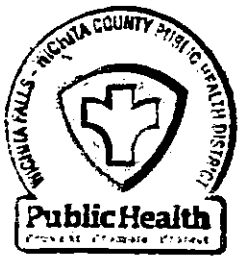

City of Wichita Falls

## Wichita Falls-Wichita County Public Health District

1000 10th St. Wichita Falls, TX 76798-2401 Phone: 817-251-2111 www.wichitafalls.tx.us

- Is the waste-water tank valve at least as big in diameter as the plumbing under sink? (1 and 1/2 or 2 inch diameter)
- Do the waste-water tank and valve retain water? If leaky, repair or replace it.
- Does the water pump work?
- Does the water heater produce hot water at sinks?
- Do the lights work?
- Do you need a generator to make these things work for the inspection?
- Is your unit's electrical plug compatible with the generator?
- Are the windows screened?
- Is there an attached, covered garbage container?
- Is the unit free of pests?

### Fire Prevention:

- Do you have a secured fire extinguisher with inspection tag?
- Is the extinguisher at least 3A40BC (conventional units using propane)? (2A10BC in the case of units not using propane)
- If you plan to deep-fry, do you have a fire suppression system? Has it been inspected?
- Do you have no smoking signs near the propane tank?

### Required Documents:

- Driver license, Proof of Insurance
- Copy of your menu
- Grease trap service contract
- Application
- Permit fee

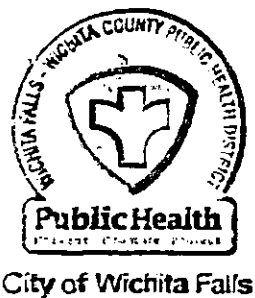

Site No. _____
Receipt No. _____
Date Rcvd. _____
For Office Use Only

## Wichita Falls-Wichita County Public Health District

### PLAN CHECK- LIST FOR CONVENTIONAL MOBILE FOOD UNITS

	One set of properly prepared plans (no larger than 11"x17") and specifications are required. Plans should be drawn to scale and must include a floor plan, plumbing diagram, finish schedule, a complete equipment lay-out with full details (including cold-hold units), and drawings of the exterior of the unit which include all items required to be shown by this document. Plans must be clear, have legible print, and not present conflicting information about the unit.
	Include a finish schedule for the floors, walls and ceilings including material, finish and color.
	Provide information on material and finish used for food preparation surfaces, counters and cabinets.
	All walls and ceilings must be smooth, easily cleanable and light in color. Utility lines, service lines, and pipes <b>shall not be unnecessarily exposed</b> (should be enclosed inside of the walls and ceilings). <b>ADD AS NOTE ON PLANS</b>
	Provide a diagram of the plumbing system including all tanks, pumps, fixtures and piping. Hot and cold running water under pressure is required.
	Provide a 2 or 3-compartment sink. (a 3-compartment sink is recommended) Each compartment must measure at least 15"x15"x12" (length x width x depth) and shall have rounded internal angles and be free of sharp corners or crevices. Add as a note on plans. Note (*All mobile food units with 2-compartment sinks must use a detergent sanitizer for utensil cleaning and sanitizing)
	Provide a hand sink separate from the 2 or 3 compartment sink.
	Indicate size and type of material used for the water supply piping.
	Provide "P" traps at sink drains. "S" traps are not acceptable.
	The fresh water tank shall be at least 30 gallons. The fresh water tank must be constructed of a food grade material (NSF or equal). The fresh water tank should be located where it can be <b>ACCESSED</b> for measuring and servicing. (no rooftop installations) The fresh water tank must be sloped to an outlet that allows complete drainage of the tank. Show physical location on plans. (If located on the outside of the unit, show the location on the exterior diagram.)
	Show the location of the fresh water inlet on the unit (exterior view). The fresh water inlet must 3/4 inch in diameter or less. The fresh water inlet must be protected from contamination and be of a size and type that will <b>PREVENT</b> its use for any other purpose. The fresh water tank vent, if provided, must terminate in a downward direction and be provided with a protective filter or screened if the termination is in an interior space.
	Show the location of a water pump. The water pump must activate automatically or be equipped with a pressure switch installed in the water supply system. Gravity systems are not acceptable. Air pressurized water systems must include a food grade on board air pump.
	Indicate what material the waste water tank is constructed of. The waste water tank must be at least 15% larger than the fresh water tank. The waste water tank must be permanently installed. The waste water tank must be sloped to drain and must be capable of being completely emptied during servicing.
	The drain outlet must be larger than any other piping in the waste water system. (Show on Exterior Diagram) The waste water tank must be located in an accessible cabinet or on the outside of the unit. (If installed on the outside of the unit, show the location on the exterior diagram.) The waste water tank should be located where it can be <b>ACCESSED</b> for measuring and servicing.

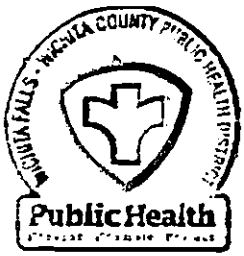

City of Wichita Falls

Site No.	_____
Receipt No.	_____
Date Rcvd.	_____
For Office Use Only	

## Wichita Falls-Wichita County Public Health District

	Provide an atmospheric vent to the outside from the top of the waste water tank. (Show on Exterior Diagram) The atmospheric vent must terminate above sink level.
	Indicate size and type of material used for the waste water drain and vent piping?
	If located within the food preparation area, the fresh water and waste water tanks must be enclosed in an <b>ACCESSIBLE</b> (for servicing or measuring) cabinet or other smooth easily cleanable structure. Show or indicate on plans.
	If located within the food preparation area, the water heater must be enclosed in an <b>ACCESSIBLE</b> cabinet or other smooth easily cleanable structure.
	Indicate how electricity be provided. (generator or plug-in at site) Provide access to electrical outlet connection so that windows & doors are not held/kept open.
	Show lighting with proper shielding (to protect against breakage) on the floor plan.
	A vent hood with removable filters (installed at an angle between 45 degrees and vertical) and mechanical ventilation to the outside is required over any grill, stove, range or fryer. Ventilation must be adequate for the equipment being vented and normally will meet specifications for a Type I, stainless steel commercial vent hood. Vent hood must have a drain and a removable catch pan along the back edge. If the hood roof attachment has an outlet for grease/ liquids, provide a drain pipe and removable, covered catch-pan on the outside of the unit. (Show on Exterior Diagram) If a fryer is used and fire suppression system must be installed.
	Any horizontal or difficult to clean space above the vent hood must be closed in.
	All openings to the outside, including serving openings and entrance doors must be screened or kept closed. Screening must be at least 16mesh/inch.
	An insect and rodent proof covered garbage container <b>SHALL BE ATTACHED</b> to exterior the MFU for patron use. It should at least be 20 gallons. (Show on Exterior Diagram.)
	<b>Note: Approval of plans does not constitute approval of the unit. Inspection of the unit is required.</b>

DIVISION 4. - MOBILE FOOD VENDORS

FOOTNOTE(S):

--- (8) ---

**Editor's note**— Ord. No. 04-2015, § 5, adopted Jan. 6, 2015, amended Div. 4 in its entirety to read as herein set out. Former Div. 4, §§ 26-570—26-606, pertained to similar subject matter, and derived from Code 2001, §§ 26-570—26-606; and Ord. No. 81-2009, § 1, adopted Nov. 3, 2009.

Sec. 26-570. - Permit requirements.

- (a) No person shall operate a mobile food establishment who does not possess a valid, current mobile food establishment permit from the regulatory authority as provided in this article. The permit for a mobile food establishment shall specify the type of food to be vended, the manner in which the food is to be vended, and include a description of any vehicle or hand-cart to be used in the food vending operation.
- (b) A person seeking a mobile food establishment permit from the regulatory authority shall make application on a form provided by the regulatory authority, and shall provide all of the information listed in the following subsections as part of the application:
  - (1) The name and address of the owner and operator;
  - (2) A copy of a current driver's license of the owner and operator, if the mobile food establishment is to be powered by a motor or towed;
  - (3) If the applicant represents a corporation, limited liability company, association, or partnership, the names and addresses of the persons responsible for the entity's operations;
  - (4) The name under which the mobile food establishment will be operated;
  - (5) A description of the type of food or the specific foods to be vended;
  - (6) The manner of mobile food vending operation to be conducted;
  - (7) A description of all vehicles to be used in the mobile food establishment operation along with the license or registration and vehicle identification number of said vehicles, and a copy of the current certificate of liability for all said vehicles;
  - (8) The address and food establishment permit number of the central preparation facility for all vehicles to be used in the mobile food establishment operation; and
  - (9) Any other information required by the regulatory authority as it pertains to the safe operation of the mobile food establishment.
- (c) Upon receiving a proper application for a mobile food establishment permit, the regulatory authority shall inspect the location, food, equipment, vehicles and other reasonable matters concerning the mobile food establishment operation and shall issue a permit and a sticker only if:
  - (1) The application complies with subsection (b) and
  - (2) The inspection reveals compliance with the applicable requirements of all federal and state statutes and regulations, and city ordinances governing the proposed mobile food establishment operation.
- (d) Fees shall be determined by the risk process level appropriate for the establishment and be in addition to any central preparation facility fees.
- (e) A valid permit sticker shall be displayed by a mobile food establishment.

- (f) Mobile food establishment permits shall be valid for one year from the date of issuance unless suspended or revoked.
- (g) Mobile food establishment permits shall not be transferred or assigned and shall be considered revoked should the character of the food vending operation be changed from that specified in the permit.
- (h) Every mobile food establishment permit shall be renewed each year in like manner as the original permit application.
- (i) The regulatory authority shall make routine, unannounced inspections of mobile food establishments, mobile food hand-carts, outdoor food courts, and commissaries when applicable, to determine whether or not the operation is being conducted in such a manner as to comply with the conditions of the permit, the provisions of this article, other applicable city ordinances and state and federal statutes, regulations and rules.
- (j) The regulatory authority may take and retain samples of food and other substances used in the preparation of food and examine it for the detection of unwholesome and deleterious qualities. The regulatory authority may condemn and forbid the sale of or cause to be removed or destroyed, any food which is adulterated, tainted, diseased, fermented, decaying or otherwise unwholesome, unclean or deleterious to health. The owner, operator or other person in charge of such food shall immediately and in the presence of the regulatory authority, destroy such adulterated, tainted, diseased, fermented, decaying or otherwise unwholesome, unclean food as directed by the regulatory authority.

(Ord. No. 04-2015, § 5, 1-6-2015)

**Sec. 26-571. - Operation requirements and restrictions.**

Mobile food establishments are subject to the following requirements and restrictions unless specifically addressed otherwise:

- (1) It shall be unlawful to operate any mobile food establishment handling open potentially hazardous foods as defined by Chapter 25 of the Texas Administrative Code, Section 228.2(74) unless the mobile food establishment is commercially manufactured.
- (2) It shall be unlawful for a person to vend on any portion of city streets where the speed limit exceeds 30 miles per hour or on four-lane divided roadways.
- (3) It shall be unlawful for a person to vend from a mobile food establishment within an "active school crossing zone" as defined by the Texas Transportation Code.
- (4) It shall be unlawful for a person to vend from a mobile food establishment unless the mobile food establishment is lawfully parked or stopped.
- (5) It shall be unlawful for a person to vend from the side of the mobile food establishment facing moving traffic. Mobile food establishments shall vend from as near as possible to the curb or edge of the street.
- (6) It shall be unlawful for a person to vend from a mobile food establishment to a person standing in the roadway.
- (7) It shall be unlawful for a person to stop a mobile food establishment on the left side of a one-way street to vend.
- (8) It shall be unlawful for a person to vend from a mobile food establishment on a street unless there is a clear view of the mobile food establishment for a distance of 200 feet in each direction.
- (9) It shall be unlawful for the owner or operator of a mobile food establishment to set up, maintain or provide service to any tables, chairs or benches for customer seating outside or within 20 feet of a mobile food establishment. This prohibition does not apply to approved outdoor food courts.

- (10) It shall be unlawful for a person to make any alteration, removal, attachments, placement or change in, under or upon a mobile food establishment that would prevent or otherwise reduce ready mobility.

(Ord. No. 04-2015, § 5, 1-6-2015)

Sec. 26-572. - Sanitation requirements for all mobile food establishments.

Mobile food establishments (including mobile food hand-carts) shall comply with the following requirements. These requirements pertain to all such establishments unless specifically addressed otherwise:

- (1) Mobile food establishments shall comply with all sanitation and construction regulations as outlined in 25 Texas Administrative Code Rule 229.166 as adopted in this chapter unless specifically addressed in this section.
- (2) A mobile food establishment shall be operated from a central preparation facility and shall report to the central preparation facility each day of operation for all cleaning and servicing operations. The mobile food establishment shall acquire needed supplies from the central preparation facility or other approved source. The mobile food establishment shall provide documentation of each visit to the central preparation facility and shall have that documentation available for inspection. Mobile food establishments dispensing fresh fish and shrimp, prepackaged novelty ice cream, whole, uncut fruit and vegetables and individual portion size nonperishable foods such as pickles, candy, peanuts and including snow cones/shaved ice/raspas are exempt from this provision.
- (3) Certain foods shall require additional equipment or sanitation procedures to ensure safety:
  - a. Mobile food establishments that sell snow cones, shaved ice, or raspas shall provide a gravity fed hand washing system, soap, and paper towels at the establishment. Such establishments shall be designed so as to enable the operator of the unit to protect the equipment, syrup, ice and utensils used in the operation of the unit from dust, insects and rodents while the unit is in transit or overnight storage.
  - b. Mobile food establishments or mobile food hand-carts that sell shrimp, fish, shellfish, or crustacea shall ensure that all such products are safe for human consumption, from an approved source, in sound condition, and free from spoilage, filth, or any other type of contamination. Shrimp shall be maintained at 41° Fahrenheit or below, and stored in either a mechanical refrigeration unit, or in ice in a clean and sanitized container with a lid. Ice must be from an approved source. Additionally, the establishment must install a three-compartment sink, plumbed with hot (minimum 110° F) and cold running water under pressure, for the purpose of cleaning and sanitizing the food contact surfaces of equipment and utensils. A handwash sink "equipped to provide water at a temperature of at least 100° F through a mixing valve or combination faucet" shall also be provided and furnished with soap and paper towels.
- (4) Liquid waste resulting from any mobile vending operation shall be stored in permanently installed retention tanks of at least 15 percent larger capacity than the water supply tank but of no less than 30 gallon capacity and shall be drained and thoroughly flushed during servicing operations. All liquid waste shall be discharged to an approved sanitary sewage disposal system at the central preparation facility.
- (5) All food that requires packaging or advance preparation by the mobile food establishment shall be processed in the central preparation facility.
- (6) Mobile food establishments which are parked and engaged in operations shall provide waste containers for customers sufficient to handle the volume of waste generated by the mobile food establishment. Waste containers shall be emptied or disposed of at the central preparation facility.

(Ord. No. 04-2015, § 5, 1-6-2015)



Sec. 26-573. - Sanitation requirements for mobile food establishments with facilities to prepare food.

Mobile food establishments preparing and vending food on-site, commonly referred to in the trade as "hot trucks," shall comply with the following additional requirements:

- (1) A mobile food establishment servicing area shall be provided at the central preparation facility, and shall include at least overhead protection for any supplying, cleaning or servicing operation. Within this servicing area, there shall be a location provided for the flushing and the draining of liquid waste separate from the location provided for water servicing and for the loading and the unloading of food and related supplies.
- (2) The central preparation facility will provide a date/time device, with associated means to record the date and time, and require each mobile food establishment that is serviced to document the date and time of arrival and departure from the central preparation facility. The mobile food establishment will make available for inspection the record of the date and time of the servicing at the central preparation facility.
- (3) Approved water storage facilities for potable water shall be provided on the mobile food establishment and shall be of sufficient capacity (minimum 25 gallons) to furnish enough water for food preparation, utensil cleaning and sanitizing, and hand washing. The water inlet shall be located in such a position that it will not be contaminated by waste discharge, road dust, oil or grease and it shall be kept capped when not being used to fill the storage facility. The water inlet shall be provided with a transition connection of a size or type that will prevent its use for any other service. All water and gas distribution pipes or tubing shall be constructed and installed in accordance with public health and plumbing standards as set out by the ordinances of the city. The water for said operations shall be from an approved source.
- (4) Either of the following shall be provided by the mobile food establishment for its operations:
  - a. A heating device of sufficient capacity to produce 110° Fahrenheit hot water; or
  - b. An instantaneous heater capable of producing 110° Fahrenheit hot water.
- (5) All operations related to the preparation of food shall be carried on from within the mobile food establishment.
- (6) Any additional equipment or the arrangement thereof other than approved when the permit was issued shall be prohibited unless approved in advance by the regulatory authority.

(Ord. No. 04-2014, § 5, 1-6-2015)