

**DUMPSTER PAD**

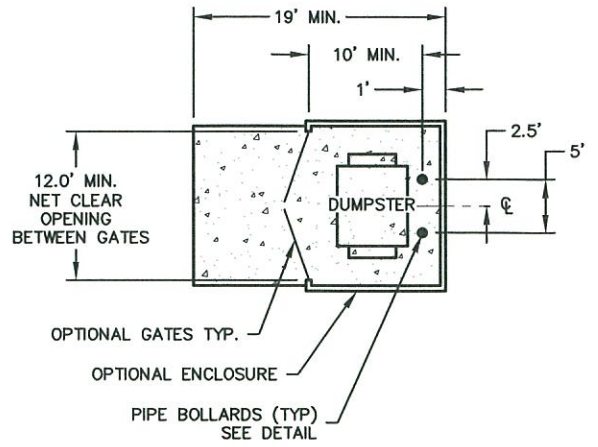

**DUMPSTER ENCLOSURE**

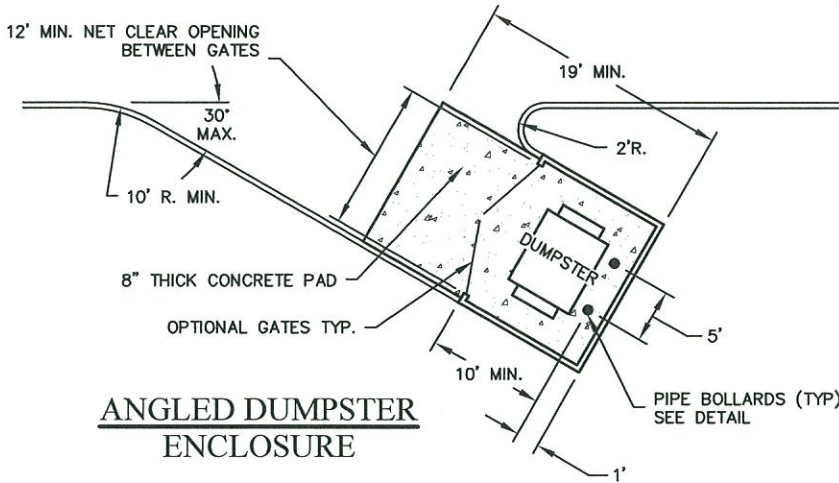

**ANGLED DUMPSTER ENCLOSURE**

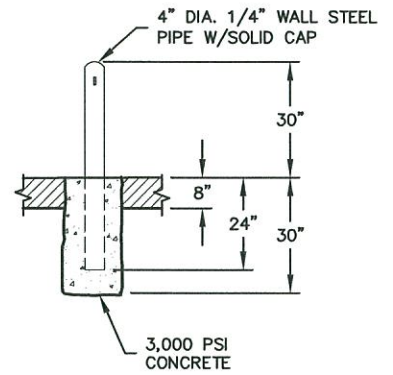

**PIPE BOLLARD DETAIL**

**GENERAL NOTES:**

1. SOLID WASTE DUMPSTER ENCLOSURE IS OPTIONAL. IF THE OWNER DESIRES AN ENCLOSURE, THIS DETAIL WILL SPECIFY THE REQUIREMENTS.
2. GATE(S) ARE NOT REQUIRED FOR ENCLOSURE. GATE(S) MUST BE DESIGNED WITH A HOLD OPEN FEATURE. GATES MUST OPEN TO GIVE A 12' MIN. CLEAR OPENING. GATES MUST BE ABLE TO OPEN TO 120°.
3. SANITATION DEPARTMENT WILL OPEN ENCLOSURES FOR COLLECTION PURPOSES BUT WILL NOT CLOSE ENCLOSURE UPON COMPLETION OF COLLECTION.
4. ENCLOSURE MUST BE DEDICATED FOR DUMPSTER USE ONLY, NO STORAGE WILL BE PERMITTED WITHIN ENCLOSURE WITHOUT PRIOR APPROVAL.
5. THERE MUST BE A 30' MIN. STRAIGHT APPROACH TO ENCLOSURE. A 50' TURN RADIUS MUST BE MAINTAINED THROUGHOUT THE PROPERTY FOR ACCESS BY SANITATION TRUCKS.
6. 8" REINFORCED, CLASS "C" CONCRETE SLAB (#4 BARS @ 18" O.C.) MUST BE PLACED UNDER AND 8' IN FRONT OF DUMPSTER PAD SITE OR ENCLOSURE.
7. THERE MUST BE NO OVERHEAD WIRES ABOVE OR WITHIN 30' OF FRONT OF ENCLOSURE. NO OVERHEAD OBSTRUCTIONS WILL BE WITHIN THE AREA NEAR THE ENCLOSURE THAT MIGHT INHIBIT TRASH PICKUP.
8. FAILURE TO FOLLOW THESE SPECIFICATIONS MAY RESULT IN THE ENCLOSURE BEING UNUSABLE BY THE CITY SANITATION TRUCKS AND REQUIRING RELOCATION OF ENCLOSURE TO AN APPROVED LOCATION ONSITE AT THE OWNERS EXPENSE.
9. SEE DETAIL 7000 FOR SOLID WASTE VEHICLE ACCESS STANDARDS.
10. DUMPSTER PAD SITE MUST HAVE A MAXIMUM OF 2% SLOPE IN ANY DIRECTION.

**SINGLE SOLID WASTE  
DUMPSTER PAD / ENCLOSURE**

NOT TO SCALE

DISCLAIMER: The use of this standard is governed by the City of Wichita Falls Engineering Department. No warranty of any kind is made by the City of Wichita Falls for any purpose whatsoever. The City of Wichita Falls assumes no responsibility for the conversion of this standard to other formats for incorrect results or damages resulting from its use.

APPROVED

*T. R. [Signature]*  
CITY ENGINEER

9-27-21  
DATE

CITY OF WICHITA FALLS, TX  
ENGINEERING DIVISION

SEPTEMBER 2021

SINGLE SOLID WASTE  
DUMPSTER PAD / ENCLOSURE

DETAIL NO. 7010